

Ignition Transformer Standard Spark-Line Secondary External (2X)

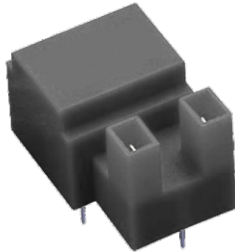

- Compact design
- Available up to 23kVpp
- To start up the ignition system of gas, oil or air
- Ambient Temperature 70°C
- No-load operation maximum up to 30 seconds
- Weight: 18g

Schematic

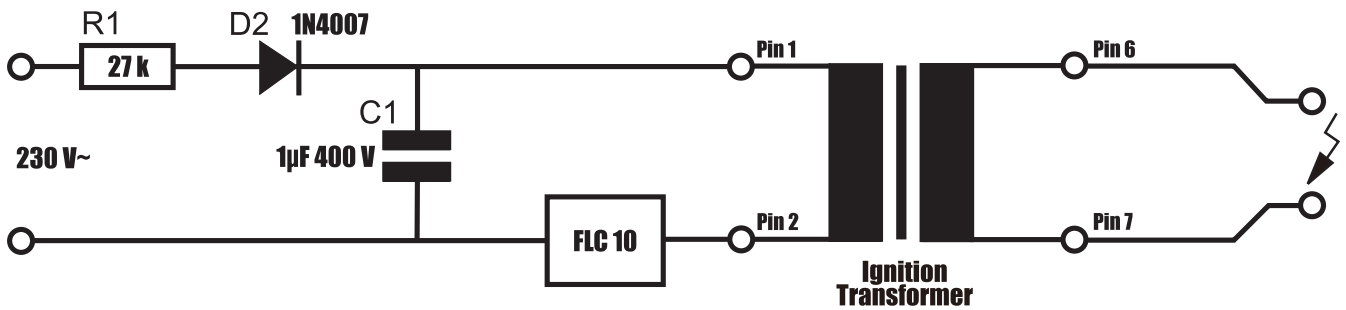

Dimensions

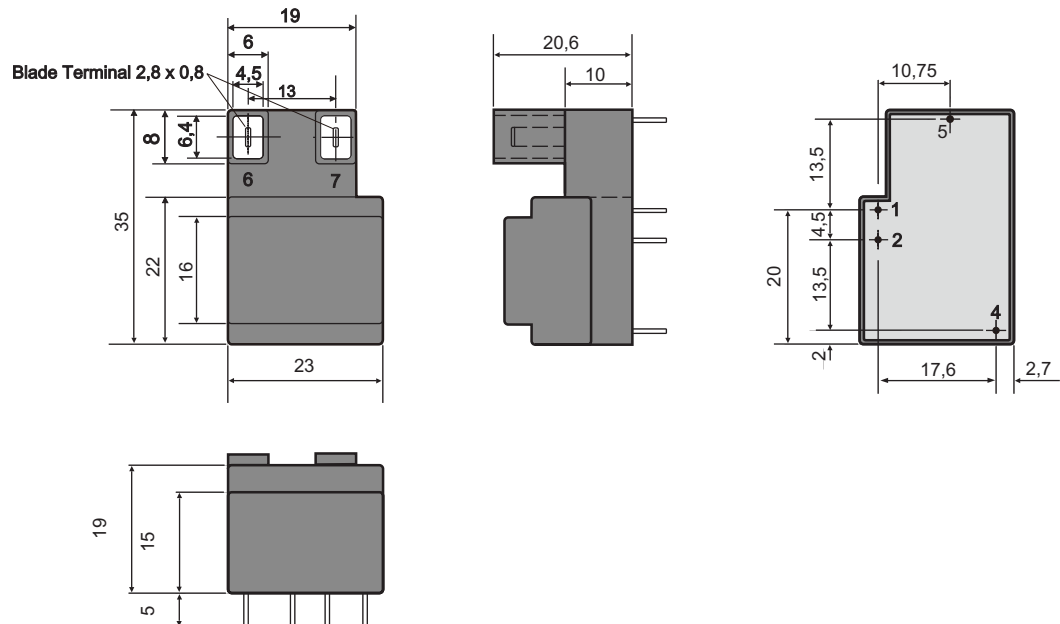

Part Number	Primary Resistance (±10%) (Pin 1-2)	Secondary Resistance (±10%) (Pin 6-7)	Primary Inductance (±15%) (Pin 1-2)	Secondary Inductance (±15%) (Pin 6-7)	Winding Ratio	Secondary Voltage @ load 30pF	Ambient Temperature	No-Load Operation (MAX)	Spark Gap (mm)
0035	26mΩ	520Ω	6µH	240mH	1:200	>22kV	70°C	30s	4~8
0049	59mΩ	822Ω	12µH	340mH	1:175	>23kV	70°C	30s	4~8